



**OPERATING, METERING, AND EQUIPMENT PROTECTION REQUIREMENTS
FOR
PARALLEL OPERATION OF
LARGE-SIZE GENERATING FACILITIES
GREATER THAN 1,000 KILOWATTS
CONNECTED TO THE DISTRIBUTION SYSTEM**

**ORANGE AND ROCKLAND UTILITIES, INC.
390 WEST ROUTE 59
SPRING VALLEY, NEW YORK 10977**

June 7, 1999

OPERATING, METERING, AND EQUIPMENT PROTECTION REQUIREMENTS
FOR
PARALLEL OPERATION OF
LARGE-SIZE GENERATING FACILITIES
GREATER THAN 1,000 KILOWATTS
CONNECTED TO THE DISTRIBUTION SYSTEM

I. INTRODUCTION

This document describes the minimum operating, metering and protective equipment which Orange and Rockland Utilities, Inc., requires for operation of its electric transmission system in parallel with a generating source or sources with total output greater than 1,000 KW.

These requirements have been established for the protection of life and property and are intended to assist owners of large-sized electric power generators (referred to hereafter as the Applicant) in evaluating their electrical generating system requirements.

A. A PROJECT BEGINS WITH THE FOLLOWING

1. When the Applicant has determined:
 - a. What type of generation (induction, synchronous, or dc with inverter).
 - b. The generator rating. (KVA, Voltage)
 - c. The amount of power to be delivered to the O&RU system.
 - d. The location of his facility.
2. Then, O&RU will determine:
 - a. The location(s) where the Applicant's facility may be connected to the O&RU system.
 - b. The ability of O&RU's facilities to accept the additional input of power.
 - c. The modifications necessary to O&RU's facilities.

- d. The requirements for voltage regulation and power factor control.
- e. The major interconnection equipment.

These considerations may result in requirements other than the general requirements provided in this document. The Applicant is encouraged to discuss his project with O&RU at the earliest possible date.

B. IT IS THE APPLICANT'S RESPONSIBILITY TO

- 1. Design, install, operate, and maintain all necessary equipment for connection to the O&RU system, unless otherwise stated in a contractual agreement.
- 2. Comply with all local, state, and federal rules, regulations, and codes which are applicable.
- 3. Submit specifications and detailed plans for the installation for the control and protective devices to O&RU for review and written approval prior to their installation and preferably before purchase.

C. INITIAL PARALLEL OPERATION WILL BE PERFORMED ONLY AFTER O&RU HAS:

- 1. Reviewed and accepted the required design documents. These must include the one-line relay and meter diagram and other pertinent protection studies (i.e., device coordination).
- 2. Inspected the completed installation.
- 3. Received and reviewed signed reports for the following:
 - a. Relay and functional trip tests: Relay test reports must show that the relay has been field tested by applying secondary currents and/or voltages at the proper frequencies. This will indicate if the relay will operate at the specified setting and within the tolerance given in the manufacturer's relay instruction bulletin.

- b. Phase-to-phase and phase-to-ground megger test:
Megger tests must be performed on the Applicant's side of the open disconnect switch to the service point, including high voltage cable runs with all of the Applicant's primary breakers and fuses racked open.
 - c. Individual megger tests: These tests must be performed on all major equipment such as primary breakers, potential transformers, station service, and auxiliary transformers.
 - d. Ratio tests: These tests must be performed on the main and auxiliary transformers.
- 4. Given written approval as stated in the appropriate power-purchase or paralleling agreement.
 - 5. Given verbal approval through the designated O&RU facility immediately prior to paralleling with the O&RU system.

These items are required to determine that the applicant's equipment can be safely connected to O&RU's system. O&RU may disconnect the facility from the O&RU system at any time if it is found that the facility is unsafe or causes interference with O&RU's system or its customers.

II. **EQUIPMENT REQUIREMENTS**

A. **METERING**

An applicant desiring to sell power to O&RU shall, subject to O&RU approval, provide, install own and maintain all facilities necessary to accommodate O&RU metering. All meters shall be provided by O&RU at the Applicant's expense. Meters shall be capable of bi-directional registration so that deliveries to an from the Applicant's equipment can be separately recorded and treated as separate

transactions under the applicable rate of price schedule.

1. The metering requirements vary with the amount of power delivered to the O&RU system. The following are the minimum requirements for metering facilities:
 - a. All facilities with a total output greater than 1,000 KW shall have equipment to:
 1. Measure and record the following:
 - a. Energy in KWH (delivered to and purchased from the applicant).
 - b. Reactive in KVAR
 - c. Power failure
 - d. Time of delivery
 2. Measure and register by a solid-state recorder:
Quantities as specified above.
 3. Customer must provide a dial-up telephone line for remote access to these devices meters by Orange and Rockland.

B. CONTROL METERING

The Company requires that all facilities connected to the distribution system shall have equipment to continuously telemeter the following data to the Company's Energy Control Center via a leased telephone line provided at the expense of the facility:

1. Instantaneous generated net real power in MW.
2. Instantaneous generated reactive power in MVAR.
3. Status of all interconnection circuit breakers and other switching devices. (When required)
4. Frequency in Hz. (When required)

Addition telemetry requirements may be imposed upon facilities to satisfy special requirements.

Telemetering of generation data is required to enable the system dispatchers to continually monitor the power system. During major disturbance or line outages, this information becomes a critical requirement in the rapid restoration of service.

This data will be provided through the installation of a REMOTE TERMINAL UNIT (RTU) in the applicant's facility. The RTU shall use DNP 3.0 protocol (unless otherwise stated). The cost of the procurement, installation, calibration and commissioning of this equipment shall be the expense of the applicant.

If a single input is required then tone equipment manufactured by Dowty RFL will be required in lieu of an RTU.

C. PROTECTIVE AND CONTROL DEVICES

Minimum protection requirements are necessary for safe and reliable parallel operation of both the facility's equipment and the Company's electric system. While most commercially available generators are equipped with some protective and control devices, additional may be required to permit parallel operation with the transmission system depending on the location, type, and size of the generator. Utility grade relays are required for all relay applications. See Figure #1 of this Appendix for a typical Interconnection Scheme.

1. All generators must have:

A. A DISCONNECT DEVICE

A disconnect device must be provided as means of electrically isolating the O&RU system from the generator and to establish working clearance for maintenance and repair work in accordance with O&RU safety rules and practices. This disconnect device may be located in the main interconnection

line, or in the generator connecting line provided it is wired directly into the main distribution bus.

The disconnect device will be installed by O&RU at the Applicant's expense.

If it is to be located in the Applicant's wiring, it must be furnished and installed by the Applicant. In either case, the disconnect device is subject to the following requirements:

1. O&RU shall approve the device to be used.
2. The device shall be physically located for ease of access and visibility to O&RU Personnel. When installed in the Applicant's wiring, the device shall normally be located in close proximity to the metering.
3. O&RU Personnel shall inspect and approve the installation before parallel operation will be permitted.
4. The device enclosure and operating handle (when present) will be kept locked at all times with O&RU padlocks.
5. Only O&RU Personnel shall operate the device.
6. The Applicant is responsible for all labor and material costs to maintain, repair or replace the disconnect device.

B. CIRCUIT BREAKER

A circuit breaker with overcurrent protection on each phase allows the applicant's generation equipment to be separated from the O&RU system.

This breaker must have sufficient interrupting capacity to interrupt maximum available fault current at its location and equipped with accessories to:

1. Trip the circuit breaker with an external trip signal supplied through a station battery (shunt trip).
2. Telemeter the status to the E.C.C. (aux. switches). (When

required)

3. Lock-out the circuit breaker when tripped by protective relays.

C. OVER AND UNDER VOLTAGE PROTECTION

This protection is used to trip the circuit breaker when the voltage is not within the relay settings.

The overvoltage protection is set to initiate a trip of the circuit breaker without a time delay when the voltage is equal to or above 110 percent of normal.

The undervoltage protection is set to initiate a trip of the circuit breaker with a 10 second time delay when the voltage is equal to or below 90 percent of normal.

D. OVER AND UNDERFREQUENCY PROTECTION

This protection is used to trip the circuit breaker when the frequency varies from the nominal of 60 Hz.

1. Overfrequency protection is set to initiate a trip of the circuit breaker, after a 1 - second time delay, when the frequency is equal to or above 62 Hz.
2. Underfrequency protection is set to initiate a trip of the circuit breaker, after a 6 cycle time delay, when the frequency is equal to or below 58.5 Hz.

E. DEDICATED TRANSFORMER

A dedicated transformer which serves only the applicant. A high side breaker is required for transformer protection. The impedance of the dedicated transformer limits the fault currents on the generator bus from the O&RU system and also limits fault currents on the O&RU system from the generator.

This requirement is site specific.

It is strongly recommended that the transformer have at least one delta winding for third harmonic suppression.

F. A GROUND FAULT SENSING SCHEME

This scheme detects ground faults and trips the circuit breaker, thus prohibiting the Applicant's generator from continuously contributing to a ground fault.

This scheme must be able to detect ground faults between the O&RU system side of the dedicated transformer and O&RU's end of line.

A transformer connected delta on the generator side and grounded wye on the system side, with appropriate relaying equipment, would provide a means of detecting system ground faults.

G. IMPEDANCE RELAY

All generators greater than 1000 KW must have an impedance relay or an overcurrent relay with voltage restraint.

These relays are used to detect phase to phase and three-phase faults, and initiate a generator circuit breaker trip. They must be located on the individual generator feeders.

H. LINE PROTECTION

Line protection relays to match the protective relays at the Company circuit breakers for the line on which the generator is connected.

These relays must be located so that a fault on any phase or all phases of the Company line will be detected.

If transfer trip protection is required, the Applicant shall provide a voice grade communications circuit for the purpose. This circuit may be leased from the

local telephone company or provided with protective features so the transfer trip equipment will operate properly during fault conditions. This equipment will be specified by O&R and procured by the facility.

I. REMOTE (SUPERVISORY) CONTROL

Generators connected to the O&R Distribution System may also be required to have:

1. Direct control of the unit output from O&R's Energy Control Center via the Remote Terminal Unit. This will allow the unit to respond to demand and to company system load changes.

SYNCHRONOUS GENERATORS

Generators facilities with synchronous generators and other generators with stand-alone capability must also have:

- a. Automatic synchronous or manual synchronization with relay supervision to synchronize with the Company's transmission system. The automatic synchronizing relay and/or the relay that supervises manual synchronization must have all the following characteristics:
 - slip frequency matching
 - voltage matching
 - phase angle acceptance
- breaker closure time compensation

Projects which are designed to operate isolated electrically from the Company system may be allowed to parallel using manual synchronization with relay supervision, provided that this relay has the same characteristics as described for the auto-synchronizing relay above.

- b. A voltage regulator: The regulator must be capable of maintaining the

generator voltage under steady-state conditions without "hunting" and within 0.5 percent of any voltage level between 90 and 110 percent of the rated generator voltage. The point of voltage sensing should be at the same point as the Company meter.

- c. A power factor controller: This device will be used when the Company determines that it is desirable for the generator to follow the system voltage while maintaining a specified power factor.

The controller must be capable at full load of maintaining a setting within 1.0 percent of any power factor setting between 0.9 lagging and 0.90 leading at the point of interconnection.

- d. The generator may be required to follow a specified voltage or VAR schedule on an hourly, daily, or seasonal basis depending in the location of the installation. Specific instructions will be provided by the Company, as required.

- 2. Synchronous generators and other generators with stand-alone capability may be required to have free-operating governors on prime movers depending on generator size and location. Free-operating governors provide added system stability. The need for free-operating governors will be determined during transient and dynamic stability simulations of the transmission system.

- 3. Single-phase generators must be connected in multiple units so that an equal amount of generation capacity is applied to each phase of a three-phase circuit.

- 4. All facilities shall comply with 1977 ANSI Standards C50.10 and C50.14 dealing with waveform and telephone interference.

5. The Company recommends that the Applicant:
 - a. Protect the generator three-phase equipment from negative sequence currents.

Certain conditions in the utility system may cause negative sequence currents to flow.

It is the sole responsibility of the facility to protect its equipment from excessive negative sequence currents.
 - b. Install differential protection and volts per Hertz protection on generator step-up transformers.

This protection scheme minimizes probability of damage due to internal faults and inadvertent over-excitation of the transformer.
6. Applicant-owned distribution voltage tap lines: If the applicant constructs, owns and maintains a distribution voltage tap line extension, then there shall be installed the following equipment at the metering point:
 - a. The fault interrupting protection device
 - b. The isolating disconnects

J. COMPANY DISTRIBUTION SYSTEM MODIFICATIONS

The Company will provide equipment and labor necessary to perform all incremental system modifications at the Facility's expense under the terms of a Special Interconnection Contract. The following modifications will normally be required:

The Company's automatic restoration equipment may be prevented from operating until the facility interconnection is severed.

Synchronous generators are capable of keeping a distribution circuit energized even after the circuit has separated from the Company system. The Company's automatic restoration equipment could attempt to restore power to the separated circuit with an instantaneous reclose. The facility's generator could be damaged, and a system disturbance could result if this were to occur on a circuit which remained energized by the generator. To prevent this, modifications to the Company's protection system may be required. The facility's generators will not be permitted to automatically re-energize the Company's distribution facilities. It will be necessary to transfer trip the facility's generator to allow the O&R system to restore. There may be other modifications required by the addition of generation to the Company transmission which are site-specific. For example, installation of generation at certain points on the distribution system may necessitate replacing circuit breakers at various places or increasing the capacity of certain transmission lines.

K. DIRECT TELEPHONE SERVICE

Direct 24 hour telephone service from the local telephone Company must be provided so that operating instructions from the Company or its operating agency can be given to the Facility or any designated operator of the Facility's equipment.

III. PERFORMANCE CRITERIA

A. HARMONIC REQUIREMENTS

The introduction of abnormal noise/harmonics can cause abnormal neutral current flow, excessive heating in motors, capacitors, transformer/relays, and switchgear/fuses. Harmonics may also cause distortion and 'jitter' in TV pictures,

telephone interference, and malfunctions in digital equipment such as computers.

All applicants generating facilities must conform to IEEE Standard 519.

B. GOVERNOR REQUIREMENTS

For Synchronous generators, the speed governor shall be capable of providing a 5 percent drop characteristic (i.e., 0.015 Hz change in the generator speed will cause a 5 percent change in the generator load). Governors must be capable of operating unrestrained to regulate system frequency.

C. POWER FACTOR REQUIREMENTS

The Company requires that generators connected to the transmission system be able to satisfy transmission load reactive requirement under all reasonable anticipated operating conditions.

Specifically, generators are required to supply sufficient lagging VARs during heavy load to satisfy both load and line lagging reactive requirements and to absorb a reasonable share of lagging VARs (produced by line charging) under light load conditions.

To insure that generators provide adequate reactive power support in proportion to their size and capability, the Company requires that generators connected to the transmission system be capable of either 1) supplying fundamental frequency power in a continuous range of .9 power factor lagging to .9 power factor leading at the point of interconnection with transmission system or .85 power factor lagging to .9 power factor leading at the generator terminal, whichever is more stringent; or 2) providing an equivalent amount of switchable reactive power support. This power factor requirement shall apply at all load levels, from minimum load to maximum load and at all voltage levels from 95% to 105% nominal system voltage.

Induction generators and other generators with no inherent VAR (reactive power)

control capability must provide supplementary reactive support equivalent to that provided by a similar-sized synchronous generator operating anywhere within the range from 90 percent leading power factor (absorbing VARs) to 90 percent lagging power factor (producing VARs), at full load. These power factors shall be calculated at the point of interconnection with the transmission system, not at the terminals of the generator.

D. VOLTAGE PROFILE

Due to design characteristics, the voltage at any given time or point on the distribution system will vary from the nominal value. Distribution planning criteria specify that voltage shall not deviate from nominal by more than 5% above or below the nominal value. As a design criterion, the expected voltage deviation should be specified as 10% in either direction during steady-state conditions.

Connecting a generator to the Company system must not cause harmful voltage fluctuations. A facility causing such harmful voltage fluctuations is subject to being disconnected from the Company's system until the condition has been corrected. Because of unusual events in the distribution system, there will be brief transient voltage fluctuations, which will resulting voltages exceeding the limits of the stated ranges. These transient voltage fluctuations, which generally last only a few milliseconds, arise due to system disturbances such as lightning strokes, clearing of faults, and other switching operations. The magnitude of transient voltage fluctuation varies with system configuration, grounding methods utilized, local short circuit availability, and other parameters which vary from point-to-point and from time-to-time on the transmission system. The expected maximum magnitude of transient over voltages is used to determine the Basic Insulation Level (BIL) if the transmission and station equipment.

The Company's minimum insulation requirements are as follows: 110KV BIL for 13.2KV equipment. An engineering study, including a Transient Network Analyzer (TNA) Study, could be performed in the station design process to demonstrate to the Company's satisfaction that lower levels of insulation are permissible. It should be noted that TNA Study may be required in conjunction with the NYPP.

E. FREQUENCY

While the Company maintains a standard 60 Hz frequency on its alternating current service, it is subject to certain deviations.

The usual maximum instantaneous deviation from the standard 60 + 2/100 cycle (+ 0.033%), except on infrequent occasions when the deviation may reach + 1/10 cycle (+ 0.17%). The usual normal deviation is approximately + 1/20 cycle (+ 0.0181%).

These conditions are subject to occur at any time of the day or night and should be considered in the design of the facility.

For synchronous machines, frequency and speed control shall be in accordance with applicable IEEE Standards.

IV. OPERATING AND MAINTENANCE PROCEDURES

A. FACILITIES IN PARALLEL OPERATION MUST HAVE

1. A daily operations log.

A log must be kept for information on unit availability, maintenance outages, circuit breaker trip operations requiring a manual reset, relay targets, and unusual event. The Company shall have the right to review these logs, especially in analyzing system disturbances.

2. MAINTENANCE SCHEDULES

All generator protective equipment must be maintained and retested at similar intervals as followed by the Company. Clearances for such tests or for unit

maintenance shall be coordinated with appropriate Company Operating Department.

3. OPERATING SCHEDULES

The voltage-VAR schedule, voltage regulator settings, and transformer ratio tap settings, as appropriate, will be supplied to the Qualifying Facility by the Company.

This information is necessary to ensure proper coordination of voltages and regulator action.

B. OUTAGES

There will be occasions where the Company shall be required to de-energize and re-energize portions of the transmission system for maintenance purposes, fault clearing and locating, testing, emergency repairs or switching operations. For these conditions and situations where time or circumstances allow, notification to Facilities will be made via established procedures. In other instances, where the Company determines that an emergency or fault condition exists, then the Company reserves the right to energize or de-energize its electrical system (or portions thereof) including any Facilities that are connected to it.

V. ADDITIONAL INFORMATION TO BE PROVIDED TO THE COMPANY

A. For all generators in Parallel Operation, the Following Shall be Provided:

1. Generator open circuit harmonic test report shall be provided with the following information:
 - a. Percent of fundamental for each single line-to-line and line-to-neutral voltage harmonic through the thirteenth harmonic.
 - b. Value of total RMS line-to-line and line-to-neutral voltage harmonics.
2. Generator impedances and time constants (synchronous generators only):

- a. Sequence impedances
 - b. Transient and subtransient impedances - both direct and quadrature-axis
 - c. Armature direct-and quadrature-axis time constants
 - d. Direct axis open-end short-circuit subtransient time constants
 - e. Open and short-circuit transient time constants for both the direct and quadrature axes
3. Transformer data including:
- a. Sequence impedance
 - b. Ratio tap settings
 - c. Voltage rating and proposed connection
 - d. Basic insulation levels
 - e. Nameplate volt ampere rating

**APPLICATION FOR ATTACHMENT OF PARALLEL
GENERATION EQUIPMENT**

1. Customer Data:

Name: _____
Phone: _____
Address: _____
Town: _____

2. Commercial Operation Rep: _____

3. Consulting Engineer or Contractor:

Name: _____
Phone: _____
Address: _____

4. Location of facility on property with a site plan _____

5. Estimated in-service date: _____

6. Existing Service: _____ Amperes: _____ Volts: _____

Proposed generator: _____

Synchronous, induction, or other: _____

Kilowatt rating: _____

Kilovolt-ampere rating: _____

Generator connection: Delta [] Wye [] Wye grounded []

Complete application action and return to your Marketing Representative along with a single line, three line or elementary diagram showing connection of all major equipment and protective devices.

7. Generator Data:

Manufacturer: _____ Model: _____

Type (Induction or Synchronous): _____

Rated Output: _____ volt-amperes

Rated Voltage: _____ volts

Rated Frequency: _____ Hertz
Rated Speed: _____ revolutions/minute
Efficiency: _____ %
Power Factor: _____ %
Rated Current: _____ amperes
Locked Rotor Current: _____ amperes
Synchronous Speed: _____ revolutions/minute
Connection of Windings: _____
(Wye or Delta)

8. Synchronous Generator:

Field Amperes _____ at rated generator voltage and amperes and _____ %PF
over excited
Type of Exciter: _____
Voltage Response: _____ (a curve may be supplied)
Output power of exciter: _____
Type of voltage regulator: _____
Direct-axis synchronous reactance (X_d): _____ ohms
Direct-axis transient reactance (X_d'): _____ ohms
Direct-axis subtransient reactance (X_d''): _____ ohms
Short circuit single phase: _____ amps
Three phase: _____ amps

9. Induction Generator:

Rotor Resistance (R_r): _____ ohms
Rotor Reactance (X_r): _____ ohms
Magnetizing Reactance (X_m): _____ ohms
Stator Resistance (R_s): _____ ohms
Stator Reactance (X_s): _____ ohms

Short Circuit Reactance (X_d'') _____ ohms
 Exciting Current: _____ amps
 Reactive Power Required: _____ VARS no load
 Phases: _____ VARS full load
 Short Circuit Single Phase _____ amps
 Three phase _____ amps

10. Inverter Data:

Manufacturer: _____ Model: _____
 Type: _____ Force Commutated _____ Line Commutated
 Rated Output: _____ Amperes _____ Volts
 Efficiency: _____ %

11. Protective Relays:

<u>Device No.</u>	<u>Manufacturer</u>	<u>Model No.</u>
<u>27</u>	_____	_____
<u>59</u>	_____	_____
<u>81</u>	_____	_____
<u>50-51</u>	_____	_____
<u>50-51N</u>	_____	_____
<u>Line Relays</u>	_____	_____

12. Dedicated Transformer

Manufacturer: _____ Voltage of Primary: _____
 Type: _____ Voltage of Secondary: _____

**TYPICAL
PROTECTION & METERING INSTALLATION
FOR GENERATORS GREATER THAN 1000KW
FOR SIMULTANEOUS PURCHASE & SALE
(When Applicant Owns The Dedicated Transformer)**

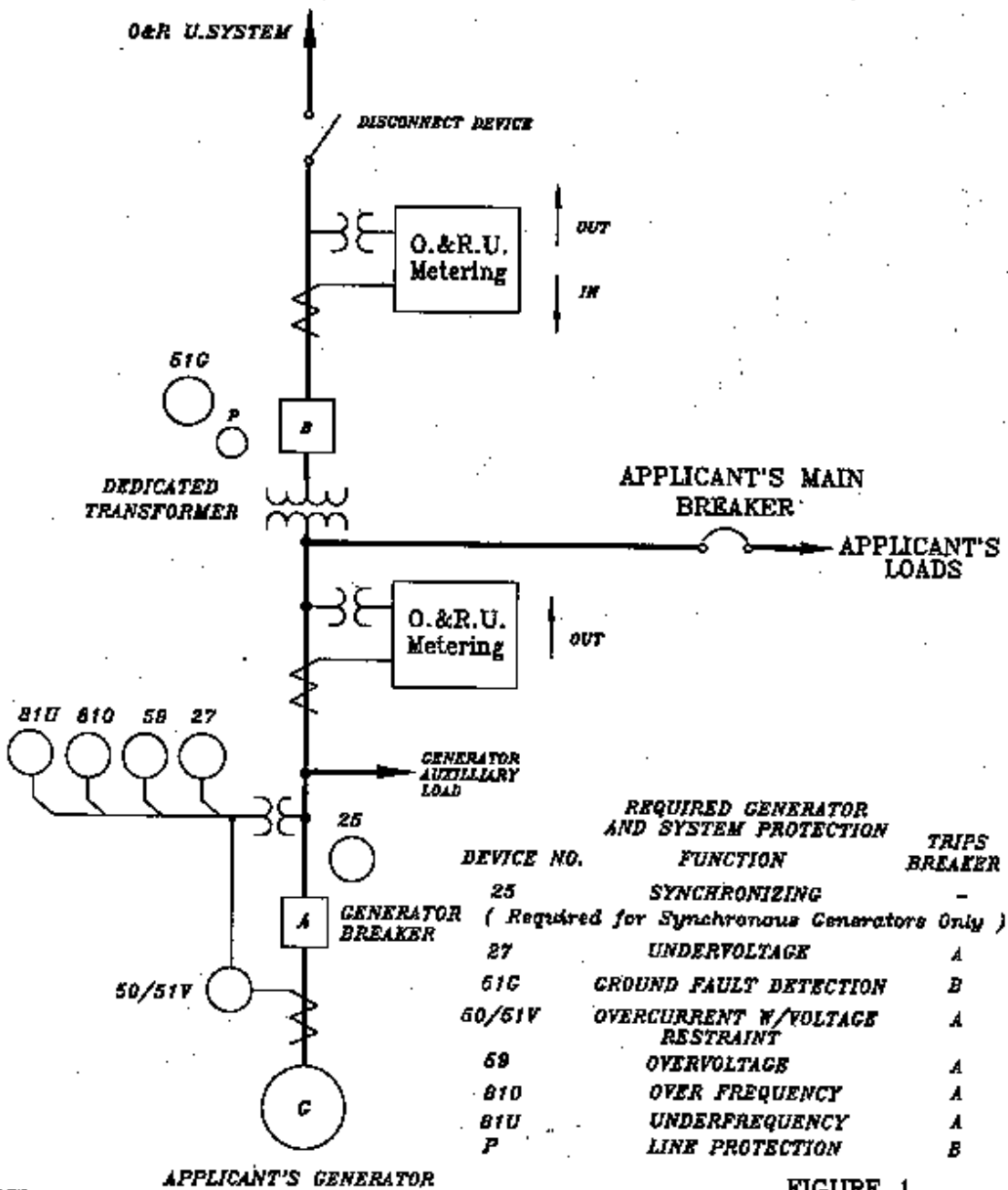
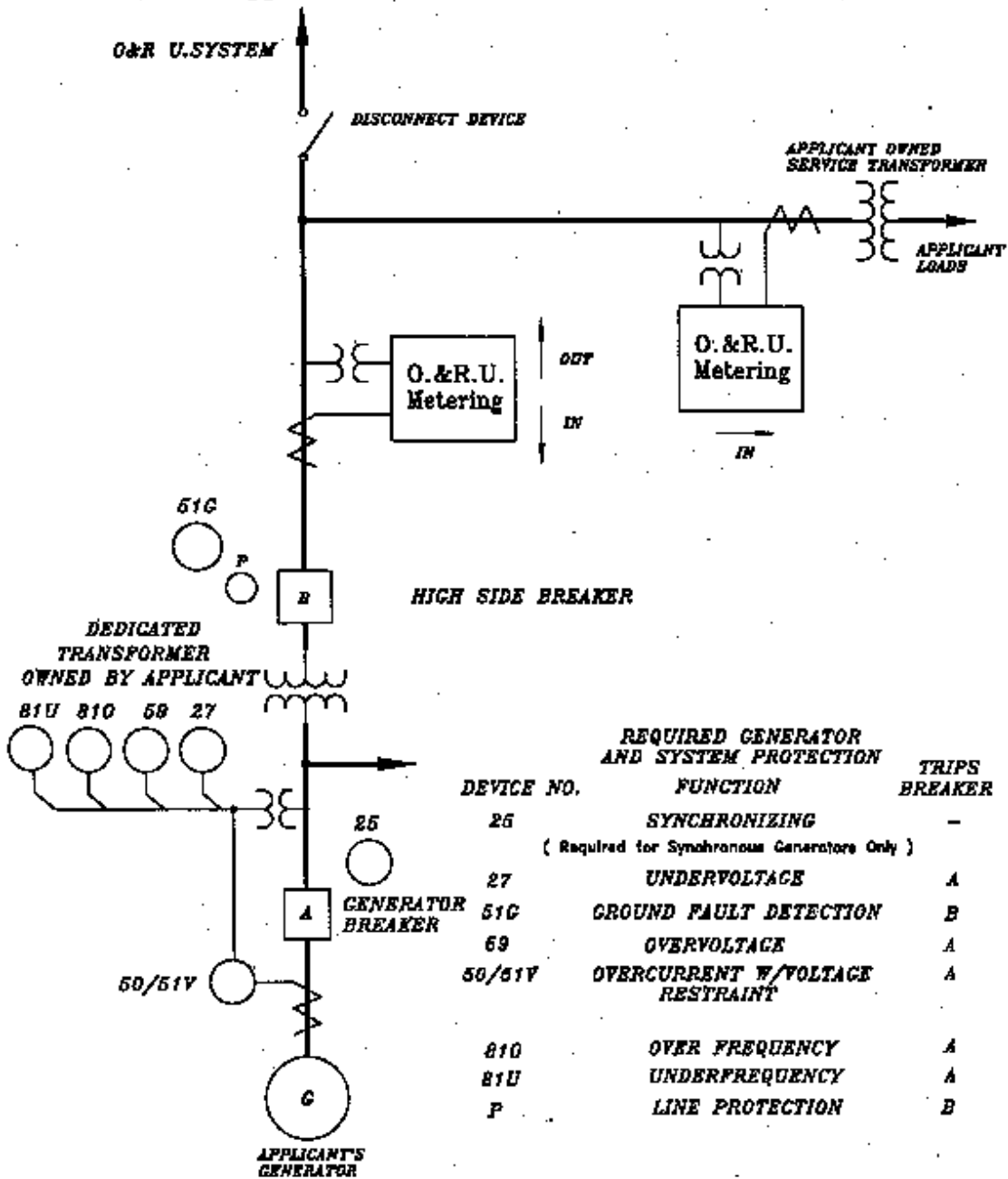
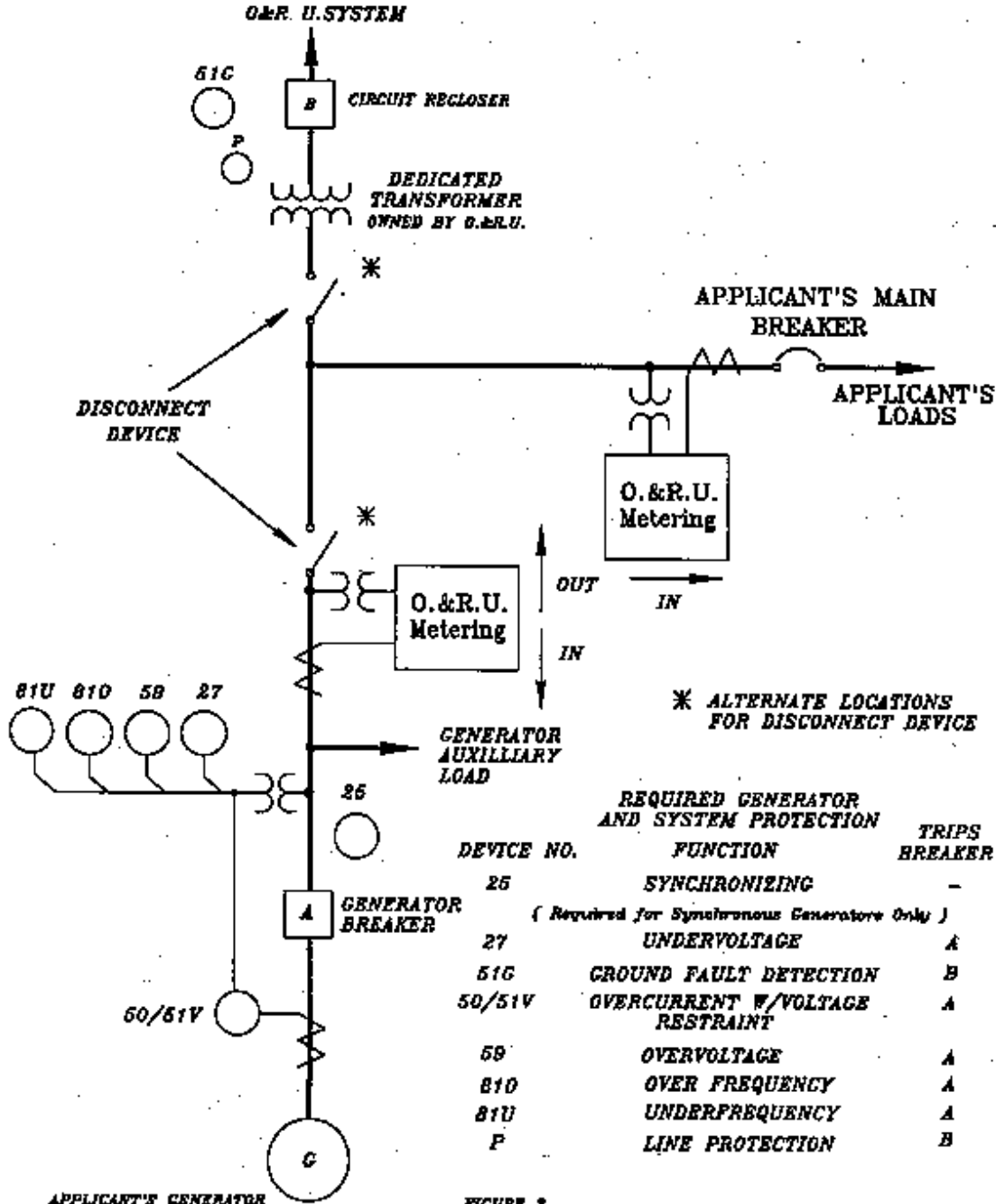

FIGURE 1

**TYPICAL
PROTECTION & METERING INSTALLATION
FOR GENERATORS GREATER THAN 1000KW
FOR SIMULTANEOUS PURCHASE & SALE
(When Applicant Owns The Dedicated Transformer)**



**TYPICAL PROTECTION & METERING INSTALLATION
FOR GENERATORS GREATER THAN 1000KW
FOR SIMULTANEOUS PURCHASE AND SALE
(WHEN O.&R.U. OWNS THE DEDICATED TRANSFORMER)**



11.00

FIGURE 3

**TYPICAL
PROTECTION & METERING INSTALLATION
FOR GENERATORS GREATER THAN 1000KW
FOR SALE OF SURPLUS ENERGY TO O&R U.
(When Applicant Owns the Dedicated Transformer)**

